



**Innovative Lighting Ideas  
Energy Efficient Solutions**



INSTALLATION GUIDE FOR:  
**OVATION SERIES 2X4 RETROFIT KIT**  
Model Number L-KVN24

# SAFETY PRECAUTIONS

READ ALL SAFETY PRECAUTIONS AND INSTALLATION INSTRUCTIONS CAREFULLY BEFORE INSTALLING OR SERVICING THIS FIXTURE KIT. FAILURE TO COMPLY WITH THESE INSTRUCTIONS COULD RESULT IN POTENTIALLY FATAL ELECTRIC SHOCK AND/OR PROPERTY DAMAGE.

DISCONNECT OR TURN OFF ELECTRICAL POWER AT THE FUSE OR CIRCUIT PANEL BEFORE INSTALLING OR SERVICING THIS FIXTURE.

ENSURE THAT ALL PRIMARY WIRES ARE CONTAINED WITHIN THE ENCLOSURE AND NO WIRES ARE PINCHED.

TO REDUCE THE RISK OF ELECTRICAL SHOCK, AND TO ASSURE PROPER OPERATION, THIS FIXTURE MUST BE ADEQUATELY GROUNDED. TO ACCOMPLISH PROPER GROUNDING, THERE MUST BE A SEPARATE GROUND WIRE (GREEN) OR BARE METAL CONTACT (METAL CONDUIT) BETWEEN THIS KIT AND THE GROUND CONNECTION OF YOUR MAIN POWER SUPPLY PANEL. THE GREEN GROUND SCREW LOCATION IS CLEARLY IDENTIFIED IN THE FIXTURE HOUSING.

HANDLE FIXTURE COMPONENTS CAREFULLY TO AVOID ANY POSSIBLE SHARP EDGE INJURY.

ONLY THOSE OPEN HOLES INDICATED IN THE PHOTOGRAPHS AND/OR DRAWINGS MAY BE MADE OR ALTERED AS A RESULT OF KIT INSTALLATION. DO NOT LEAVE ANY OTHER OPEN HOLES IN AN ENCLOSURE OF WIRING OR ELECTRICAL COMPONENTS.

THIS RETROFIT KIT IS SUITABLE FOR FIELD INSTALLATION IN ANY RECESSED FLUORESCENT LUMINAIRE WITH NOMINAL OVERALL DIMENSIONS 48 IN (1219 MM) LONG BY 24 IN (609 MM) WIDE.

## WARNING

RISK OF FIRE OR ELECTRIC SHOCK

LUMINAIRE WIRING AND ELECTRICAL PARTS MAY BE DAMAGED WHEN DRILLING FOR INSTALLATION OF LED RETROFIT KIT. CHECK FOR ENCLOSED WIRING AND COMPONENTS.

## WARNING

RISK OF FIRE OR ELECTRIC SHOCK

LED RETROFIT KIT INSTALLATION REQUIRES KNOWLEDGE OF LUMINAIRES ELECTRICAL SYSTEMS. IF NOT QUALIFIED, DO NOT ATTEMPT INSTALLATION. CONTACT A QUALIFIED ELECTRICIAN. A QUALIFIED ELECTRICIAN MUST PERFORM ALL WIRING AND INSTALLATION IN ACCORDANCE WITH NATIONAL AND LOCAL ELECTRICAL CODES.

## WARNING

RISK OF FIRE OR ELECTRIC SHOCK

INSTALL THIS KIT ONLY IN THE LUMINAIRES THAT HAVE THE CONSTRUCTION FEATURES AND DIMENSIONS SHOWN IN THE PHOTOGRAPHS AND/OR DRAWINGS.

## WARNING

TO PREVENT WIRING DAMAGE OR ABRASION, DO NOT EXPOSE WIRING TO EDGES OF SHEET METAL OR OTHER SHARP OBJECTS.



PRIOR TO INSTALLATION, VERIFY THE CONTENTS OF THE RETROFIT KIT BY CONFIRMING THAT YOU HAVE THE FOLLOWING COMPONENTS:

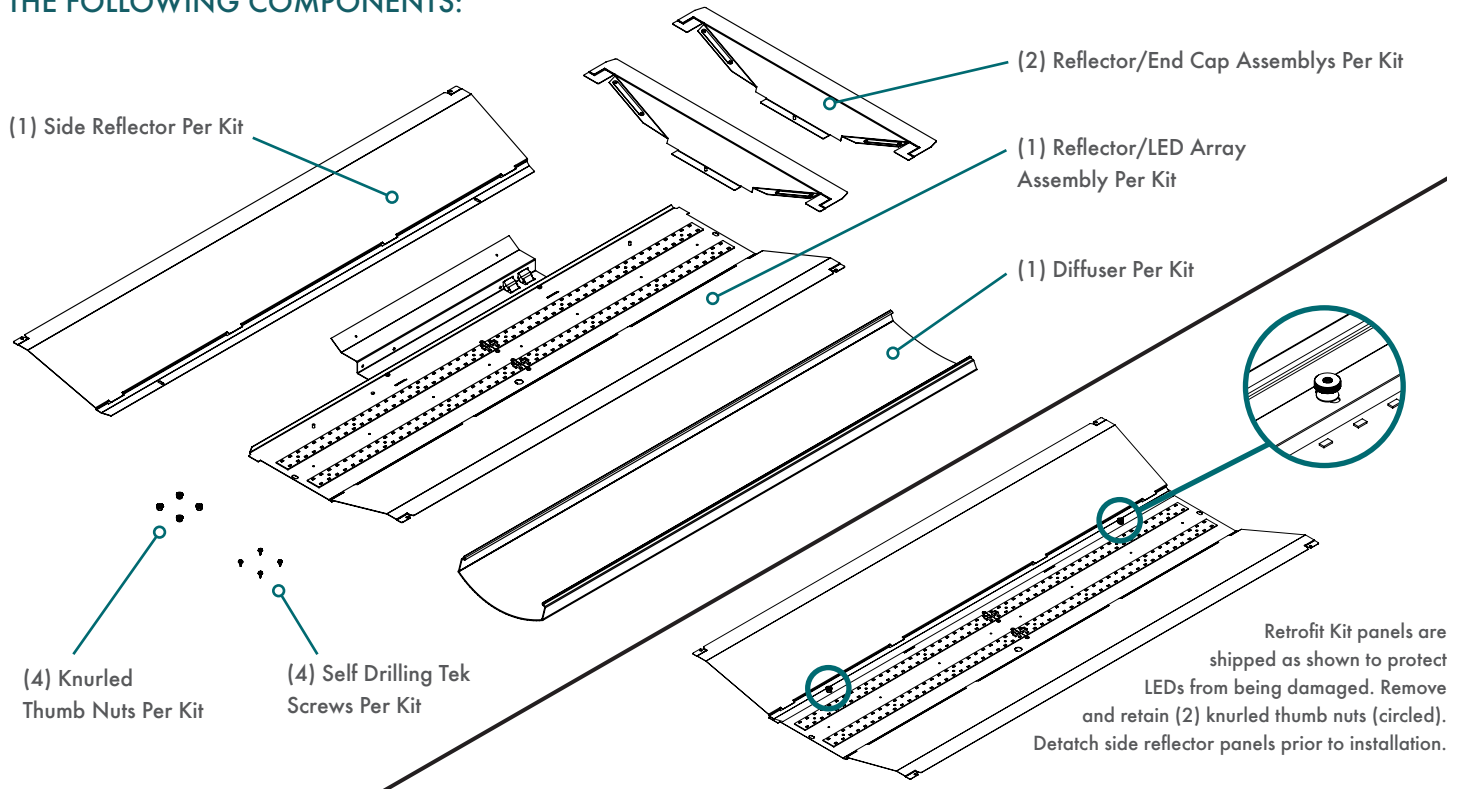

## STEP 1: FIXTURE PREPARATION

FOLLOW STEPS "A" THROUGH "D" AS SHOWN.

Remove ballast, lamp holder brackets, lamp holders and lamp holder leads

Remove reflector and ballast cover

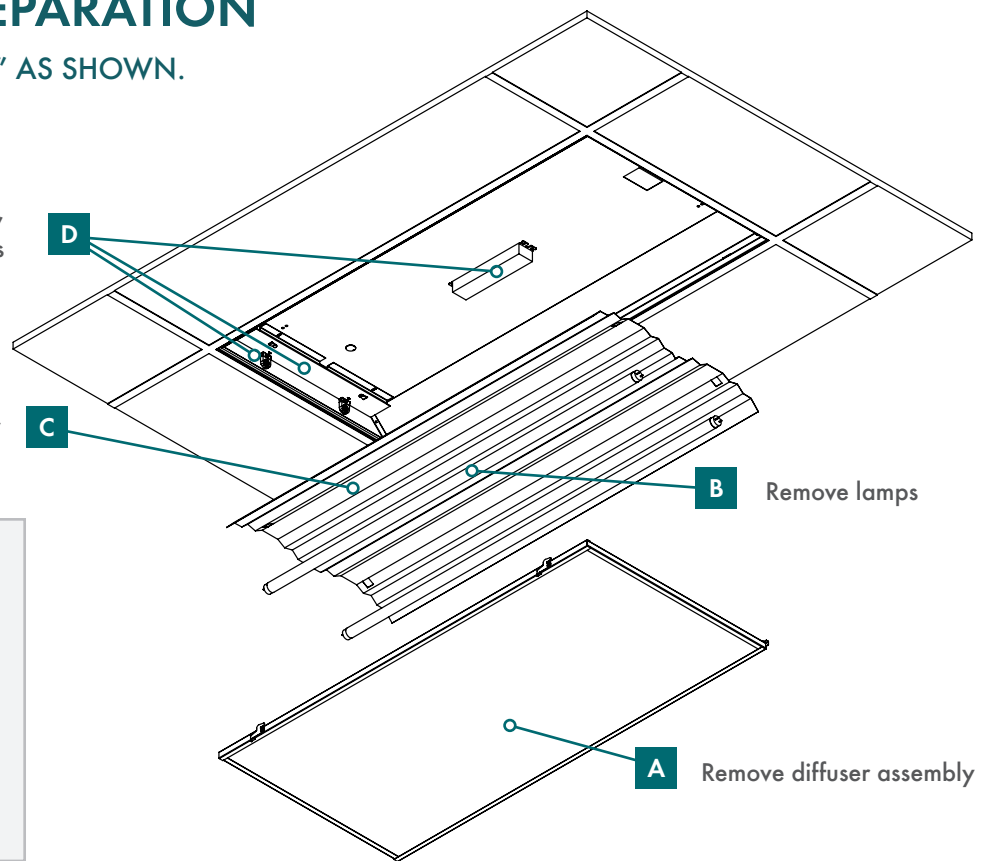

### **CAUTION**

TO AVOID SHOCK OR INJURY, DISCONNECT ELECTRICAL POWER AT SUPPLY PANEL BEFORE INSTALLING OR SERVICING ANY PART OF THIS FIXTURE.



## STEP 2: HARDWARE INSTALLATION

FOLLOW STEPS "A" AND "B" AS SHOWN.

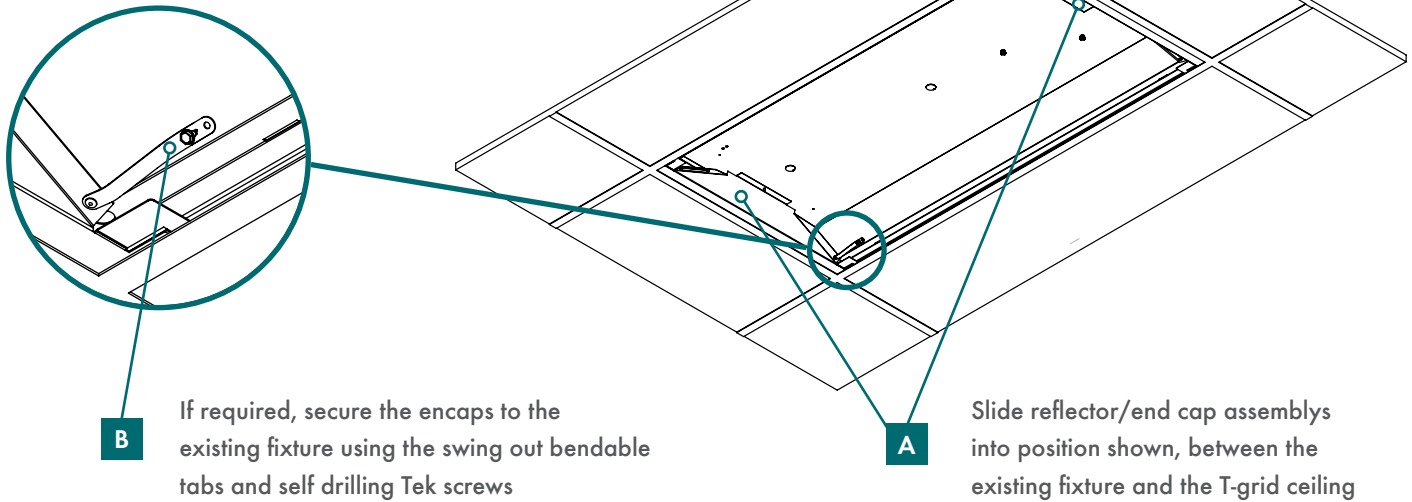

## STEP 3: REFLECTOR/LED ARRAY ASSEMBLY INSTALLATION

FOLLOW STEPS "A" THROUGH "C" AS SHOWN.

CONNECT GROUND AND POWER LEADS  
(SEE DRAWING AT BOTTOM-RIGHT).

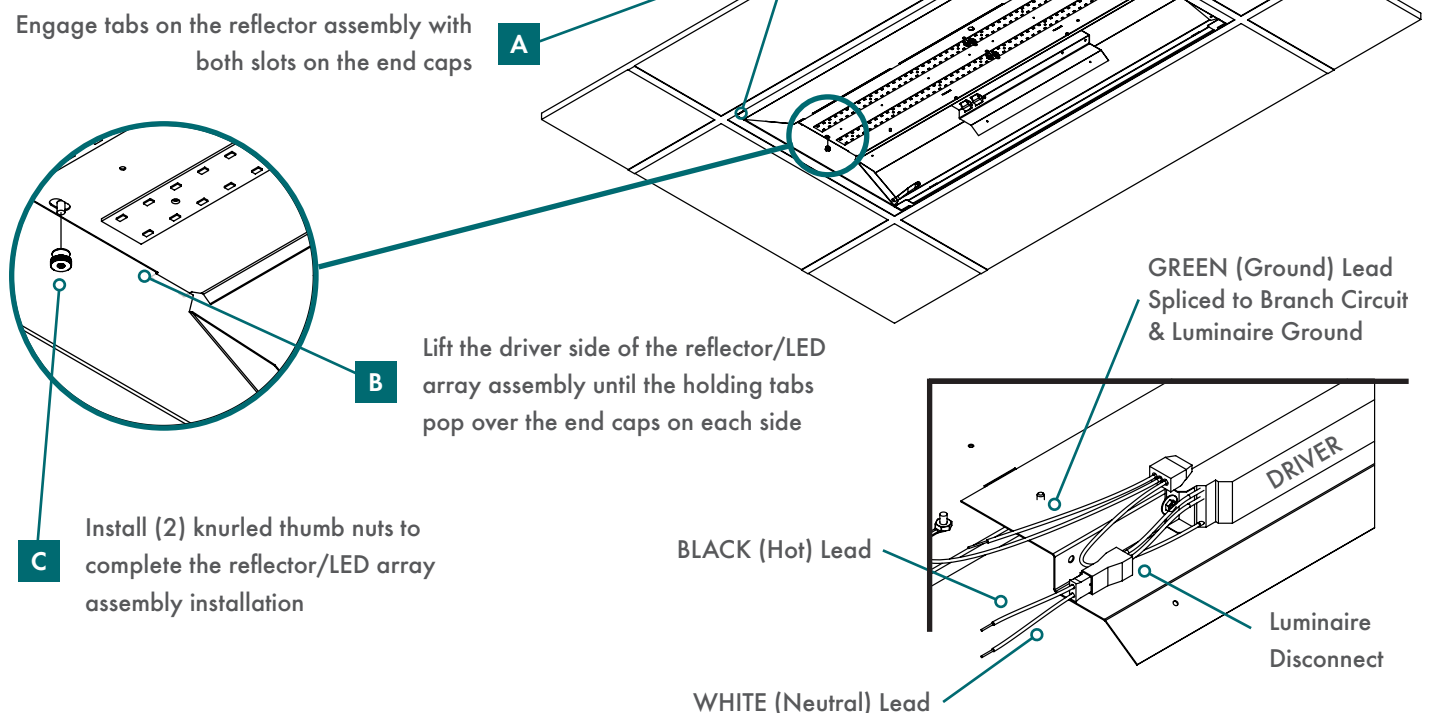

## STEP 4: SIDE REFLECTOR INSTALLATION

FOLLOW STEPS "A" AND "B" AS SHOWN.

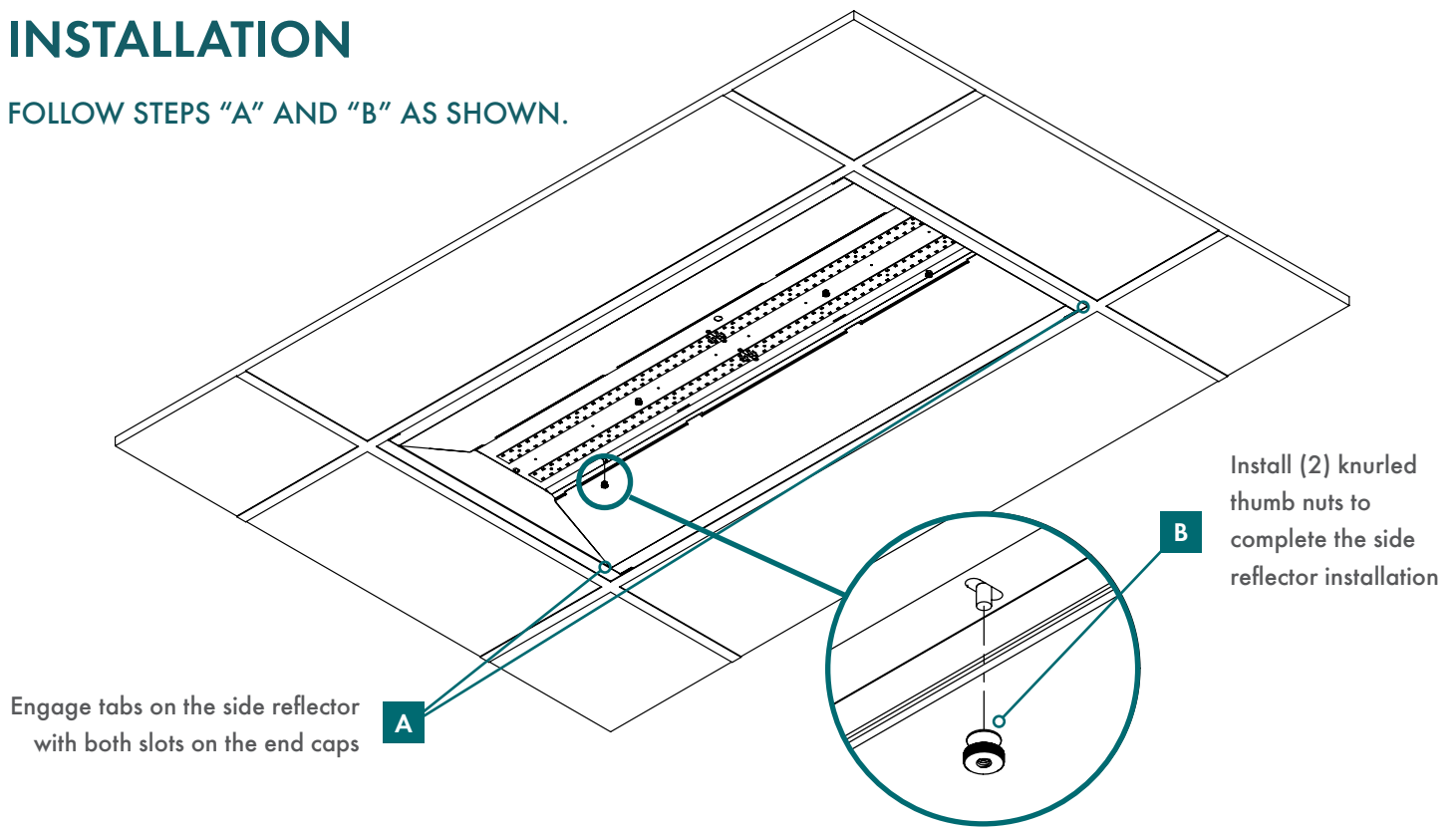

## STEP 5: COMPLETE INSTALLATION

FOLLOW STEPS "A" AND "B" AS SHOWN.

- A** Install new diffuser
- B** Turn power on and verify proper operation

